

<b>ANDREX INC</b>	<b>Material Specification</b>		
	NUMBER AX-108	REV B	SHEET 1 of 4

TITLE:  Strip, Non-magnetic, Stainless Steel, Alloy UNS S30403 (Type 304L), .0032	WRITTEN BY: J.B. 10/16/89	
	ENG APPROVAL: J.B. 12/22/89	
THIS DOCUMENT IS THE PROPERTY OF ANDREX, INC. THIS IS PROPRIETARY INFORMATION AND SHALL NOT BE REPRODUCED OR USED FOR MANUFACTURING, EXCEPT AS MAY BE OTHERWISE PROVIDED BY CONTRACT.	CAGE CODE <b>2W880</b>	QC APPROVAL: JRHorn 12/21/89

<u>Revision</u>	<u>Description</u>	<u>Date</u>	<u>Approved</u>
-	Release to Production	12/22/89	J.B.
A	ECN-H176: Revised to add dash numbers for each width.	01/26/99	W.M.B.
B	ECN-H277: Revised para 5.2 packaging requirements ECN-H291: Revised para 5.1 coiling requirements	08/16/04	W.M.B.

<b>ANDREX INC</b>	<b>Material Specification</b>		
	NUMBER AX-108	REV B	SHEET 2 of 4

**1. SCOPE.**

- 1.1 Scope. This specification defines the requirements for stainless steel strip for use in the production of strip wound conduit.
- 1.2 Classification. Part Numbers under this specification are coded as follows:

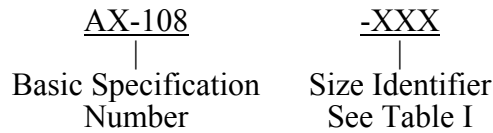

**2. APPLICABLE DOCUMENTS.**

This section does not apply to this specification.

**3. REQUIREMENTS.**

Material shall be stainless steel per UNS S30403 as specified herein.

3.1 Chemical Analysis Requirements:

C:	0.03% max.
Cr:	18.0-20.0%
Mn:	2.0% max.
Ni:	8.0-12.0%
P:	0.045% max.
S:	0.03% max.
Si:	1.0% max

3.2 Physical Analysis Requirements:

Tensile Strength:	75,000 psi min.
Yield:	36,000 psi min.
Elongation:	30% in 2 inches, min.
Hardness:	Soft annealed
Thickness:	.0032±.0003
Width:	As specified in Table I

**TABLE I**

Size Identifier	Width
-210	.210 +.001/-.003
-250	.250 +.001/-.003
-4125	4.125 ±.015

<b>ANDREX INC</b>	<b>Material Specification</b>		
	NUMBER AX-108	REV B	SHEET 3 of 4

3.3 Material Workmanship:

Material shall be clean and matte finished. Must be free from oil, grease, and foreign matter, dents, cracks surface flaws and scratches. Vendor slit material shall have the slit edges turned up not more than 30% of material thickness.

**4. QUALITY ASSURANCE PROVISIONS.**

4.1 Quality Assurance shall be responsible for inspection of material upon receipt of each lot for conformance to this specification, or unless otherwise specified by any requirements stated on the lot's specific purchase order.

**5. PREPARATION FOR DELIVERY.**

5.1 Coiling Requirements:

All coils shall be wound of unspliced material. Standard width sheet coils and vender slit coils shall have a coil outside dimension of 14" to 20". All coils shall have an inside dimension of 4" or 6". Coils with an O.D. of 10" to 14" will be accepted, provided that they do not constitute more than 10% of any single shipment. Coils under 10" will be rejected. Every effort should be made to supply coils with the largest O.D. possible but not to exceed the 20" O.D. maximum.

5.2 Packaging:

Shipping pallet must be made to accommodate lift forks with a 30" outside dimension. Pallet shall weigh no more than 1,500 lbs. Each pallet is to be protected from moisture and physical damage during shipment. All coils must lay flat in a horizontal manner. 4-1/8" coils must not be stacked. See Figure 1.

- Outer Coil Wrap (A)
- Cardboard Core (B)
- Roll Edge Covercaps (C)
- Skid Liner (D)
- Coil Seal Protectors (E)

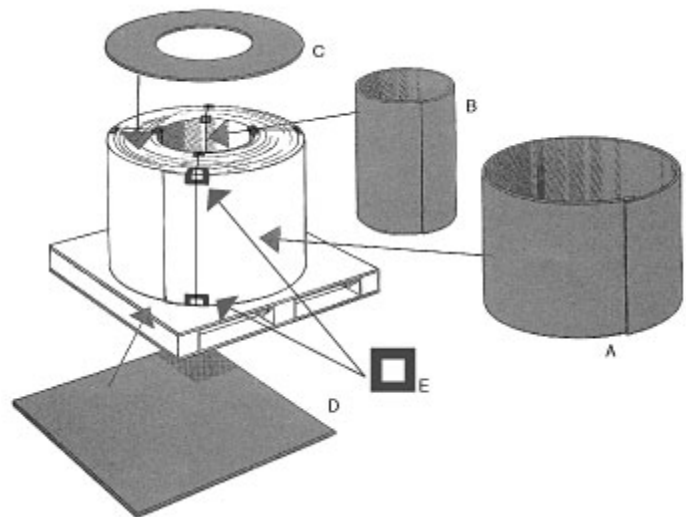

Figure 1

<b>ANDREX INC</b>	<b>Material Specification</b>		
	NUMBER AX-108	REV B	SHEET 4 of 4

5.3 Certification:

Certificate of Compliance and Analysis Test Report must accompany each shipment.

**6. NOTES.**

6.1 Ordering Information: Purchase orders should specify the following:

- a. Part Number including size identifier (see 1.2)
- b. Description
- c. Quantity, total poundage.
- d. Delivery Date